

WHEELS & BRAKES

4" GERDES ALUMINUM WHEEL

Aluminum wheel with 3/4" tapered timken bearing. Use 3/4" axle. Weight 2.3 lbs. Uses 2.80 x 2.50 x 4 tire and tube. As used on VariEze, LongEze, Cosy Classic, Cozy or 10 x 3.50 x 4 tire and tube as used on Cozy Mark IV.



| DESCRIPTION | PART NUMBER | PRICE EA |
|--------------------|-------------|----------|
| 4" wheel | NWA-1230 | 61.54 |
| REPLACEMENT PARTS: | | |
| Bearing race | LM11910 | 3.95 |
| Bearing assembly | LM11900LA | 15.20 |

4" GERDES ALUMINUM WHEEL KIT

Includes 1 - 4" nose wheel with bearings, 2 - 4" main wheels with bearings, 2 brake rotors, 2 brake calipers with brake pucks. All wheels with 3/4" id timken roller bearings. Use with 4" tires listed on tire pages. 11 lbs.



| DESCRIPTION | PART NUMBER | PRICE EACH |
|--------------|-------------|------------|
| 4" wheel kit | GS-4K | 145.00 |

NOSEWHEEL CLEVELAND

6" Aluminum with 1-1/2" bearing. Use 1-1/2" axle assembly. For 600 x 6 tires.



| DESCRIPTION | PART NUMBER | PRICE EACH |
|-------------------|-------------|------------|
| Aluminum assembly | CWB40-56 | 536.40 |

NOSEWHEEL ASSEMBLY CLEVELAND

For use with tube-type tires. Each has 1-1/4" bearing, use 1-1/4" axle. Aluminum or magnesium. Magnesium NOT compatible with salt. For 500 x 5 tires.



| DESCRIPTION | PART NUMBER | PRICE EACH |
|-------------|-------------|------------|
| Magnesium | CWB40-77C | 310.00 |
| Aluminum | CWB40-87C | 398.00 |

4" AZUSALITE - AZUSA

Made of space-age glass reinforced Zytel Nylon combines very high tensile and compression strength and good impact resistance making them worthy of comparison with similar die cast aluminum. Black in color, has precision ball bearing which is top quality for higher speed with no lubrication. 4" wheel: 1-3/8" od, 5/8" id, ball bearing. .957 lbs per wheel. 2-3/4" width, uses 5/8" axle. Axle does not require a spacer. For ultralight use only. Cannot be used with Azusa brakes.



| DESCRIPTION | PART NUMBER | PRICE EACH |
|---------------|-------------|------------|
| 4" wheel | AZ-1053 | 20.85 |
| Axle | AZ-582 | 24.00 |
| 5/8" axle nut | AN365-1011A | 2.84 |
| 5/8" washer | AN960C-1016 | 3.00 |

5" ALUMINUM AZUSA WHEEL - 3/4" BEARING

AZ-1137 all aluminum ball-burnished finish, split rim wheels have bead biting edges to prevent slipping. 3.75" - 3 bolt pattern with 3/4" id tapered roller bearing. 5" tire size, 3.12" bead width, maximum width 3.7", wheel diameter 6", hub width 2.90", total weight 2.902 lbs. Includes nuts and bolts for mounting. **No brakes:** use AZ-3410 axle.



Wheel & Brake kit consists of 2 each: AZ-1137 wheels, AZ-2272A brake assemblies, AZ-2211 drums.

Kits with axles also include 2 each: AZ-347 axles, AZ-34114 spacers, AN960C-1216 washers, AN365-1210A coarse nuts.

| DESCRIPTION | PART NUMBER | PRICE EA. |
|-------------------------------|-------------|-----------|
| 5" Wheel/Brake kit (no axles) | AZ-11371 | 125.32 |
| W/B kit with Axles & hardware | AZ-11372 | NLA |

REPLACEMENT PARTS

| | | |
|-----------------------------------|---------|-------|
| 5" wheel 3/4" bearing | AZ-1137 | 26.65 |
| 3/4" axle - NO BRAKES used | AZ-3410 | NLA |

Parts used WITH BRAKES:

| | | |
|-------------------------------|-------------|-------|
| 3/4" axle for use with brakes | AZ-347 | NLA |
| Axle spacer | AZ-34110 | NLA |
| Axle nut coarse thread | MS17829-12C | 4.77 |
| Washer for axle | AN960C-1216 | 9.23 |
| Brake assembly round - 4-1/2" | AZ-2272A | 27.95 |
| Drum without flange | AZ-2211 | 8.06 |

5" ALUMINUM GROVE

Aluminum wheel and brake kit by Grove. A high quality wheel and brake kit for the homebuilder. 1-pc brake discs, machined from solid steel for smoother braking, use standard 66-106 pads. 500x5 wheels are precision machined from A356 T6 structural aluminum for maximum corrosion resistance and sized to fit standard 1-1/4" axles. Static Load rating per wheel: 1250 lbs. Kinetic energy brake rating: 118, 164 joules. Spare parts are available. For experimental aircraft only.



| DESCRIPTION | PART NUMBER | PRICE EACH |
|------------------|-------------|------------|
| 500 x5 Wheel Kit | 50-1 | 549.00 |

WHEELS & BRAKES

5" AZUSALITE - AZUSA WHEEL 5/8" BEARING



Made of space-age glass reinforced Zytel Nylon combines very high tensile and compression strength and good impact resistance making them worthy of comparison with similar die cast aluminum. Black in color, has precision ball bearing which is top quality for higher speed with no lubrication. **5" wheel** - 1-3/8" od, 5/8" id. bearing 1.263 lbs per wheel. 3" wheel width. Includes nuts and bolts for mounting. **No brakes:** use AZ-582 axle **Wheel & Brake kit** consists of 2 each: AZ-1057 wheels, AZ-2259A platforms, AZ-2270A brake assemblies and AZ-2211 drums.

Kits with axles also include 2 each: AZ-583 axles, AZ-58214 spacers, AN960C-1016 washers, AN365-1011A coarse nuts, 4 each: AN4C-5A bolts, and MS21044C4 nuts.

| DESCRIPTION | PART NUMBER | PRICE EACH |
|-------------------------------|-------------|------------|
| 5" Wheel/Brake kit (no axles) | AZ-10571 | 137.48 |
| W/B Kit with Axles & hardware | AZ-10572 | NLA |

REPLACEMENT PARTS:

| | | |
|-----------------------------------|---------|-------|
| 5" wheel - 5/8" bearing | AZ-1057 | 25.70 |
| 5/8" axle - NO BRAKES used | AZ-582 | 24.00 |

Parts used WITH BRAKES:

| | | |
|-------------------------------|-------------|-------|
| 5/8" axle for use with brakes | AZ-583 | 28.50 |
| Spacer for axle | AZ-58214 | 2.66 |
| Axle nut coarse thread | AN365-1011A | 2.84 |
| Washer | AN960C-1016 | 3.00 |
| Brake Platform | AZ-2259A | 8.74 |
| Brake drum w/o flange | AZ-2211 | 8.06 |
| 5" Wheel/Brake kit (no axles) | AZ-11371 | 0.00 |
| W/B kit with Axles & hardware | AZ-11372 | 0.00 |

REPLACEMENT PARTS

| | | |
|-----------------------------------|-------------|-------|
| 5" wheel 3/4" bearing | AZ-1137 | 26.65 |
| 3/4" axle - NO BRAKES used | AZ-3410 | NLA |
| Parts used WITH BRAKES: | | |
| 3/4" axle for use with brakes | AZ-347 | NLA |
| Axle spacer | AZ-34110 | NLA |
| Axle nut coarse thread | MS17829-12C | 4.77 |
| Washer for axle | AN960C-1216 | 9.23 |
| Brake assembly round - 4-1/2" | AZ-2272A | 27.95 |
| Drum without flange | AZ-2211 | 8.06 |

5" ALUMINUM GROVE



High performance 5" wheel and brake kit suitable for heavier aircraft or those with higher landing speeds. Dual piston brake calipers provide 36% more braking power than the Model 50-1, and use longer lasting 66-111 brakes pads. Thicker 1-pc brake discs absorb more heat, thereby reducing brake fade. Precision machined aluminum wheels include high quality timken tapered roller bearings, and fit standard 500x5 1-1/4" axles. Static load rating per wheel: 1250 lbs. Kinetic brake energy: 205,146 joules. Spare parts are available. For experimental aircraft only.

| DESCRIPTION | PART NUMBER | PRICE EACH |
|----------------------|-------------|------------|
| High performance kit | 56-1 | 689.00 |

UPGRADE KIT



For use with 500 x 5 tire size. Up grades the CWB199-102 kit (CWB40-78B, CWB30-9) to the new CWB40-230 and CWB30-181 specs. Kit includes 164-099 discs, linings, shims, bolts, rivets and nameplates.

| DESCRIPTION | PART NUMBER | PRICE EACH |
|-------------|-------------|------------|
| Upgrade kit | CWB199-093 | 325.25 |

5" ALUMINUM GROVE



Ultra High-Performance kit designed for the demands of heavier aircraft and/or high landing speeds. Dual piston brake calipers provide 83% more braking power than the model 50-1. Grove's thickest 1 -pc brake discs absorb the most heat energy of all their kits, for maximum reduction of brake fade. Uses the larger, longer service 66-111 pads. Precision machined 500x5 aluminum wheels are rated at 1250 lbs of static load per wheel. Kinetic brake energy: 246,715 joules. Fits standard 1-1/4" axle. For experimental aircraft only.

| DESCRIPTION | PART NUMBER | PRICE EACH |
|----------------------------|-------------|------------|
| Ultra High performance kit | 57-1 | 749.00 |

5" ALUMINUM - AZUSA WHEEL - 5/8" BEARING



AZ-1144 all aluminum, beautifully ball burnished for sparkle. Has bead biting edges and pips to prevent tire and tube slippage; the split rim design allows low cost and simple tire change. 3 bolt pattern, 1-3/8" od, 5/8" id precision ball bearing. Use 5/8" axle. Weight 2 lbs 7-1/2 oz. Includes nuts and bolts used to mount drum. **No Brakes:** use AZ-581

Wheel & Brake kit consists of 2 each: AZ-1144 wheels, AZ-2270A brake assemblies, AZ-2211 drums.

Kits with axles also include 2 each: AZ-585 axles, AZ-58114 spacers, AN960C-1016 washers, AN365-1011A coarse nuts, 4 each: AN4C-5A bolts, MS21044C4 nuts. As used on KR2 - add TR100-040 tires and TB100-040 tubes, no axles

| DESCRIPTION | PART NUMBER | PRICE EACH |
|----------------------------|-------------|------------|
| Wheel/Brake Kit (no axles) | AZ-11441 | 0.00 |
| With axles & hardware | AZ-11442 | 0.00 |

REPLACEMENT PARTS

| | | |
|-----------------------------------|-------------|-------|
| 5" wheel - 5/8" bearing | AZ-1144 | 25.38 |
| 5/8" axle - NO BRAKES used | AZ-581 | NLA |
| Part used WITH BRAKES: | | |
| 5/8" axle used with brakes | AZ-585 | NLA |
| Spacer for axle | AZ-58114 | NLA |
| Axle nut coarse thread | AN365-1011A | 2.84 |
| Washer | AN960C-1016 | 3.00 |
| Brake assembly | AZ-2270A | 26.24 |
| Drums | AZ-2211 | 8.06 |

5" MAGNESIUM CLEVELAND



500 x 5 kit with magnesium wheel, aluminum brakes. Static capacity, 1,260#, limit load 4550-lbs. Weight per kit 10.80 lbs. Brake rating in kinetic energy capacity 117,500 ft-lb. Each kit contains 2: CWB40-78B wheel assemblies which include 2: CWB164-117 discs, and 2: CWB30-9 brake assemblies with 4: CWB66-106 lining. Chrome discs available by ordering CWB199-102C. Other kit items the same. Use AX5 - 1-1/4" axles, 2- A484 spaces per axle and MS21025-20 nuts. NOT compatible with SALT.

| DESCRIPTION | PART NUMBER | PRICE EACH |
|-----------------------|-------------|------------|
| 500 x 5 kit Magnesium | CWB199-102 | 625.26 |
| WITH Chrome disc | CWB199-102C | 839.25 |

WHEELS & BRAKES

5" ALUMINUM CLEVELAND

500 x 5 kit with aluminum wheels and brakes - heavy duty. Static capacity 1,260#, limit load 4550-lbs. Weight per kit 12.40 lbs. Brake rating in kinetic energy capacity 117,500 ft-lb. Each kit contains 2: CWB40-78A wheel assemblies which include 2: CWB164-17 discs, and 2: CWB30-9A brake assemblies with 4: CWB66-106 linings. Chrome discs available by ordering CWB199-103C. Other kit items the same. Use AX5 - 1-1/4" axles, 2-A484 spacers per axle and MS21025-20 nut



| DESCRIPTION | PART NUMBER | PRICE EACH |
|----------------------|--------------------|----------------|
| 500 x 5 kit Aluminum | CWB199-103 | 1004.41 |
| W/chrome discs | CWB199-103C | 1214.40 |
| Dust cover | CWB157-8 | 22.40 |

5" MAGNESIUM CLEVELAND

500 X 5 kit - super heavy duty, magnesium wheel and brake. Static capacity 1,260#, limit load 4550-lbs. Brake rating in kinetic energy capacity 192,000 ft-lb. Kit contains 2: CWB40-151 wheel assemblies which include 2: CWB164-85 discs, and 2: CWB30-133 brake assemblies with 4: CWB66-105 linings. Use AX5 - 1-1/4" axles, 1 - A484 spacer & 1 A484-4357 per axle with MS21025-20 nut. NOT compatible with SALT.



| DESCRIPTION | PART NUMBER | PRICE EACH |
|--------------------------|-------------------|---------------|
| 500 x 5 kit HD Magnesium | CWB199-152 | 812.07 |

CLEVELAND UPGRADE KIT

Converts the 30-133 brake assembly (as used in the CWB199-152) to a 30-164 high energy brake assembly. Kit includes: 4 ea 66-062 linings, 8 ea 177-003 pins, 4 ea 103-117 bolts, 4 ea 95-104 washers and 2 nameplates



| DESCRIPTION | PART NUMBER | PRICE EACH |
|-------------------|-------------------|---------------|
| Brake upgrade kit | CWB199-196 | 199.99 |

5" MAGNESIUM-CLEVELAND HIGH ENERGY

500 x 5 super high energy magnesium wheel and brake kit. Static load capacity: 1260, limit load: 4550 lbs. Brake rating in kinetic energy capacity: 289,000 ft/lbs. Each kit contains 2: CWB40-151 wheel assemblies which include 2 CWB164-85 discs, and 2 CWB30-164 brake assemblies with 4: CWB66-62 metallic linings. Use AX5 1-1/4" axles, 1- A484 spacer and 1-A484-4357 spacer per axles with MS21025-20 nut.



| DESCRIPTION | PART NUMBER | PRICE EACH |
|----------------------------------|-------------------|---------------|
| 500 x5 kit High Energy Magnesium | CWB199-197 | 898.60 |

5" MAGNESIUM CLEVELAND

Heavy duty wheel and brake kit. Static capacity 1,260#, limit load 4550-lbs, brake rating in kinetic energy capacity 155,000 ft-lb. Kit contains 2: CWB164-99 discs, 2: CWB30-181 brake assemblies with 4 - CWB66-106 linings. Use AX5, 1-1/4 axles, 1: A484 spacer and 1: A484-4375 spacer and MS21025-20 nut per axle. NOT compatible with SALT.500 x 5 kitHD Magnesium



| DESCRIPTION | PART NUMBER | PRICE |
|-------------------------|-------------------|---------------|
| 500 x 5 kitHD Magnesium | CWB199-156 | 797.13 |

6" ALUMINUM GROVE

A high-quality 600x6 wheel and brake kit for the homebuilder. Brake calipers are CNC machined from solid aluminum bar stock and use standard 66-105 pads. 1-pc brake discs are machined from solid steel for smoother braking. Braking power rating: 186,800 joules kinetic energy. corrosion-resistant aluminum wheels are precision machined from A3356T6 structural aluminum and fit standard 1-1/2" axles. Static load rating per wheel: 1750 lbs. Spare parts available.



| DESCRIPTION | PART NUMBER | PRICE EACH |
|------------------------|-------------|---------------|
| 600 x6 wheel/brake kit | 60-1 | 819.00 |

6" AZUSA WHEEL 3/4" TAPERED BEARING

All aluminum, beautifully, ball-burnished for sparkle and have bead biting edges and pips to prevent ire and tube slip. The split-rim design allows low cost and simple tire changing. AZ-1105 has 3 bolt pattern with 3/4" tapered roller bearing, Weight 4.2 oz. Use 3/4" axle.



Wheel & Brake kit consists of 2 each: AZ-1105 wheels, AZ-2272A brake assemblies, AZ-2211 drums.

Kits with axles also include 2 each: AZ-348 axles, AZ-34138 spacer, AN960C-1216 washers, AN365-1210A coarse nuts, 4 each: AN4C-5A bolts, MS21044C4 nuts.

| DESCRIPTION | PART NUMBER | PRICE EACH |
|-------------------------------------|--------------------|--------------|
| AZ-1105: Wheel/Brake kit (no axles) | AZ-11051 | 0.00 |
| With Axles & hardware | AZ-11052 | 0.00 |
| REPLACEMENT PARTS | | |
| 6" wheel - 3/4" tapered bearing | AZ-1105 | 44.40 |
| Axle use NO BRAKES | AZ-344 | 28.50 |
| Parts used WITH BRAKES: | | |
| 3/4" axle use with brakes | AZ-348 | NLA |
| Spacers for axle | AZ-34138 | NLA |
| Axle nuts coarse thread | AN365-1210A | NLA |
| Washer | AN960C-1216 | 9.23 |
| Brake assembly | AZ-2272A | 27.95 |
| Drums | AZ-2211 | 8.06 |

WHEELS & BRAKES

6" AZUSA WHEEL - 3/4" STANDARD BEARING



All aluminum, beautifully, ball-burnished for sparkle and have bead biting edges and pips to prevent tire and tube slip. The split-rim design allows low cost and simple tire changing. AZ-1127 has 3 bolt pattern with 3/4" standard ball bearings. Weight 3.625 lbs, 4" width. Use 3/4" axle.

Wheel & Brake kit consists of 2 each: AZ-1127 wheels,, AZ-2272A brakes, AZ-2211 drums.

Kits with axles also include 2 each: AZ-348 axles, AZ-34114 spacers, AN960C-1216 washers, AN365-1210A nuts, 4 each: AN4C-5A bolts, MS21044C4 nuts

| DESCRIPTION | PART NUMBER | PRICE EACH |
|--------------------------------|-------------|------------|
| 6" Wheel/Brake Kit | AZ-11271 | 162.58 |
| With Axles & hardware | AZ-11272 | NLA |
| REPLACEMENT PARTS | | |
| 6" wheel - 3/4" standard | AZ-1127 | 45.28 |
| 3/4" axle - NO BRAKES | AZ-344 | 28.50 |
| Parts used WITH BRAKES: | | |
| 3/4" axle- use with brakes | AZ-348 | NLA |
| Spacers for axle | AZ-34114 | NLA |
| Axle nuts coarse thread | AN365-1210A | NLA |
| Washer | AN960C-1216 | 9.23 |
| Brake assembly | AZ-2272A | 27.95 |
| Brake drums | AZ-2211 | 8.06 |

6" AZUSA WHEEL 5/8" BALL BEARING



All aluminum, beautifully, ball-burnished for sparkle and have bead biting edges and pips to prevent tire and tube slip. The split-rim design allows low cost and simple tire changing. Available in the following: AZ-1125 have 3 bolt pattern, 1-3/8" od, 5/8" id, precision ball bearing. Weight 3.656 lbs., 4" width to be used with wider tires. Use 5/8" axle.

Wheel & Brake kit consists of 2 each: AZ-1125 wheels, AZ-2270A brake assemblies, and AZ-2211 drums.

Kits with axles also include 2 each: AZ-586 axles, AZ-58138 spacers, AN960C-1016 washers, AN365-1011A nuts, 4 each: AN4C-5A bolts, MS21044C4 nuts.

| DESCRIPTION | PART NUMBER | PRICE EACH |
|--------------------------------|-------------|------------|
| 6" Wheel/Brake Kit | AZ-11251 | 155.60 |
| With Axles & hardware | AZ-11252 | NLA |
| REPLACEMENT PARTS | | |
| 5/8" sealed ball bearing | AZ-1125 | 43.50 |
| 5/8" axle - NO BRAKES | AZ-5811 | 28.50 |
| Parts used WITH BRAKES: | | |
| 5/8" axle - use with brakes | AZ-586 | NLA |
| Spacers for axle | AZ-58138 | 2.66 |
| Axle nuts coarse thread | AN365-1210A | NLA |
| Washer | AN960C-1216 | 9.23 |
| Brake assembly | AZ-2270A | 26.24 |
| Brake drum | AZ-2211 | 8.06 |

6" AZUSALITE - AZUSA WHEEL - 5/8" BORE



Made of space-age glass reinforced Zytel Nylon combines very high tensile and compression strength and good impact resistance making them worthy of comparison with similar die cast aluminum. Black in color, has precision ball bearing which is top quality for higher speed with no lubrication.

6" wheel - 1-3/8" od, 5/8" id, 5/8" bore, 1.671 lbs. per wheel, 2-3/4" width. Wheel & Brake kit consists of 2 each: AZ-1072 wheels, AZ-2270A brakes, AZ-2211 drums.

Kits with axles also include: 2 each: AZ-583 axles, AZ-58178 spacers, AN960C-1016 washer, AN365-1011A coarse nuts, 4 each: AN4C-5A bolts, MS21044C4 nuts.

| DESCRIPTION | PART NUMBER | PRICE EACH |
|----------------------------------|-------------|------------|
| 6" Wheel/Brake kit (no axles) | AZ-10721 | 128.40 |
| With Axles & hardware | AZ-10722 | NLA |
| REPLACEMENT PARTS | | |
| 6" wheel - 5/8" bore | AZ-1072 | 29.90 |
| 5/8" axle - use NO BRAKES | AZ-581 | NLA |
| Axle space for AZ-581 axle | AZ-5834 | 2.66 |
| Parts used WITH BRAKES: | | |
| Axles -use with brakes | AZ-583 | 28.50 |
| Spacers for axles | AZ-58178 | 2.66 |
| Axle nuts coarse thread | AN365-1011A | 2.84 |
| Washer | AN960C-1016 | 3.00 |
| Brakes | AZ-2270A | 26.24 |
| Drums | AZ-2211 | 8.06 |

8" AZUSA WHEEL 5/8" BEARING



All aluminum, beautifully ball-burnished for sparkle and have bead biting edges and pips to prevent tire and tube slip. The split-rim design allows low cost and simple tire changing. 8" wheel has 3 bolt pattern with 5/8" id precision ball bearings. Weight 2.813, 3" width. Uses 5/8" axle.

Wheel & Brake kit consists of 2 each: AZ-1175 wheels, AZ-2530 brake assemblies, AZ-2542 drums. **Kits with axles** also include 2 each: AZ-585 axles, AZ-58114 spacers, AN960C-1016 washers, AN365-1011A coarse nuts, 4 each: AN4C-5A bolts, MS21044C4 nuts.

| DESCRIPTION | PART NUMBER | PRICE EACH |
|---------------------------------------|-------------|------------|
| 8" wheel/brake kit (no axles) | AZ-11751 | 154.90 |
| With axles & hardware | AZ-11752 | NLA |
| REPLACEMENT PARTS | | |
| 8" wheel | AZ-1175 | 34.04 |
| 5/8" axle - use with NO brakes | AZ-581 | NLA |
| Parts used with brakes: | | |
| 5/8" axle - use with brakes | AZ-585 | NLA |
| Axle nut | AN365-1011A | 2.84 |
| Axle spacer | AZ-58114 | NLA |
| Brake assembly | AZ-2530 | 28.95 |
| Drums | AZ-2542 | 11.95 |

WHEELS & BRAKES

6" ALUMINUM - CLEVELAND

600 x 6 wheel and brake kit has static capacity 1,500#, limit load 6000-lbs. Weight per kit 18.50-lbs. Brake rating in kinetic energy capacity 200,000 ft-lb. Each kit contains 2: CWB40-113X wheel assemblies which include 2: CWB164-40 discs, and 2: CWB30-75X brake assemblies with 4 - CWB66-105 linings. Kit available with CWB164-40 chrome disc - #CWB199-105C. Uses AX6 - 1/12" axles and MS21025-24 nut.

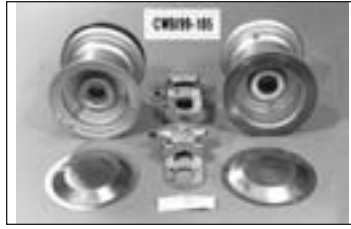

| DESCRIPTION | PART NUMBER | PRICE EACH |
|---------------------|-------------|------------|
| 600 x6 kit Aluminum | CWB199-105 | 891.95 |
| W/chrome discs | CWB199-105C | 998.30 |
| Dust cover | CWB157-9 | 33.82 |

6" MAGNESIUM/ALUMINUM - CLEVELAND

600 x 6 kit with magnesium wheel and aluminum brake. Static capacity 2,500#. Kit used on defiant aircraft. Weight per kit 19.90 lbs. Each kit contains 2- CWB40-75B wheel assemblies with 2: CWB164-15A discs and 2: CWB30-52 brake assemblies which include 8 - CWB66-105 linings. Kit also includes 2 ea CWB10-34 master cylinders. USE AX6 - 1-1/2" axle and MS21025-24 nut. Magnesium NOT compatible with salt.



| DESCRIPTION | PART NUMBER | PRICE EACH |
|----------------------------|-------------|------------|
| 600 x 6 Magnesium/Aluminum | CWB199-133X | 1304.71 |

6" MAGNESIUM CLEVELAND

600 x 6 wheel and brake kit has static capacity 1,750#, limit load 6000-lbs. Weight per kit 16.36-lbs. Brake rating in kinetic energy capacity 185,000 ft-lb. Each kit contains 2: CWB40-59A wheel assemblies which include 2: CWB164-175 discs, and 2: CWB30-59A brake assemblies with 4 - CWB66-112 linings. Kit available with chrome discs CWB164-175 in kit CWB199-104C. Use AX6 - 1-1/2" axles and MS21025-24 nut.



| DESCRIPTION | PART NUMBER | PRICE EACH |
|-----------------------|-------------|------------|
| 600 x 6 kit Magnesium | CWB199-104 | 893.72 |
| W/chrome discs | CWB199-104C | 1035.00 |

6" MAGNESIUM CLEVELAND

600x6 kit with magnesium wheels and aluminum brakes. Static capacity: 2500 lbs. Each kit includes 2 each: CWB40-75B wheel assemblies, CWB164-15A brake discs, CWB30-52 brake assemblies with CWB66-105 linings. Use 1-1/2" AX6 axles and MS21025-24 nuts. Magnesium NOT compatible with salt.



| DESCRIPTION | PART NUMBER | PRICE EACH |
|-----------------------|-------------|------------|
| 600 x 6 Magnesium Kit | CWB199-253 | 1388.15 |

KR2 WHEEL KIT

Kit consists of 2 each of the following, AZ-1144 wheels, AZ-2270 brakes, AZ-2211 drums, 2 ea 6 ply Lamb tires and tubes. Use 5/8" axle. As used on the KR-2 aircraft.



| DESCRIPTION | PART NUMBER | PRICE EACH |
|-------------|-------------|------------|
| Kit | KR200-011 | 170.56 |
| 5" wheel | AZ-1144 | 25.38 |
| Brakes | AZ-2270A | 26.24 |
| Drums | AZ-2211 | 8.06 |
| Tires | TR100-040 | 16.99 |
| Tubes | TB100-040 | 8.90 |

BOBCAT/SUPERCAT WHEEL KIT

Aluminum kit consists of 2 each of the following: AZ-1175 wheels, AZ-2530 brakes, AZ-2542 drums, tires: 4.80 x 4.00 x 8, tubes and miscellaneous hardwares. Use 5/8" axle. Kit as used on Bobcat or Supercat aircraft. 400 lb.



| DESCRIPTION | PART NUMBER | PRICE EA |
|-------------|-------------|----------|
| Kit | BC100-405 | 223.03 |
| 8" wheels | AZ-1175 | 34.04 |
| Brakes | AZ-2530 | 28.95 |
| Drums | AZ-2542 | 11.95 |
| Bolts (6) | AN5-11A | 0.39 |
| Washers (6) | AN960-516L | 1.01 |
| Nuts (6) | MS20365-524 | 0.22 |
| Tire | TR100-080 | 25.00 |
| Tube | TB100-080 | 6.73 |

$$\text{KINETIC ENERGY} = \frac{.44 \times W \times V^2}{N}$$

W = Landing Weight in Pounds

V = Landing Speed in Knots

N = Number of Wheels with Brakes

To select the proper brake system for your airplane, use the formula above to calculate the kinetic energy absorbed by the brakes during maximum braking.

Example: Aircraft landing weight of 1600 lbs. landing at 60 knots = kinetic energy of 126,720 foot pounds

WHEELS & BRAKES

HYDRAULIC FLUID RESERVOIR

One piece welded aluminum construction. 1-1/4" diameter, 2-1/2" high, with 1/8" NPT male outlet at bottom and filing port with unvented plug at top. Suitable for normal or inverted flight. Capacity 1.4 oz, Weight 1.8 oz, can be threaded directly into master cylinder port. Two units required on most installations or one per each master cylinder.



| DESCRIPTION | PART NUMBER | PRICE EACH |
|---------------|-------------|------------|
| Side outlet | A-600 | 14.74 |
| Bottom outlet | A-700 | 13.66 |

ALUMINUM BRAKE FLUID RESERVOIR

Available with choice of filter port location for firewall or floor mounting, capacity is 5 oz. Size 2-1/4" diameter, 2-1/2" long. Weight 8 oz.



| DESCRIPTION | PART NUMBER | PRICE EACH |
|----------------|-------------|------------|
| Floor mount | A315-R1 | 39.95 |
| Firewall mount | A-315R | 34.14 |

HYDRAULIC FLUID RESERVOIR

Matco reservoir made of clear polycarbonate plastic for easy visual inspection of fluid level. Firewall mount.

Also available in a kit containing reservoir, 83" of 1/4x035 nylon tubing., 1-268P connector, 1- 264P tee and 2 - 269P elbows.



| DESCRIPTION | PART NUMBER | PRICE EACH |
|-------------|-------------|------------|
| Reservoir | MTR-100 | 24.56 |
| Kit | MTR-100K | 41.95 |

WHEEL CLEANERS

MET-ALL POLISH

A professional grade non-abrasive polish for use on any aluminum or stainless steel surface. Removes and prevents oxidation and guards against water spotting. Cleans accumulated surface dirt and stains from anodized aluminum, leaving a lustrous, long lasting finish. Non-flammable and environmentally safe.



| DESCRIPTION | PART NUMBER | PRICE EACH |
|-----------------|-------------|------------|
| 1 lb can polish | METALL-1 | 12.99 |

NEVER-DULL

Chemically impregnated cotton wadding manufactured under a special process. Acts both as a solvent and mechanical cleaner. Removes corrosion, carbon exhaust marks, wax, tar, grease, rain marks, grit, any petroleum product. Also removes deposits around rivets and along skin joints. Only one application and then wipe clean; no severe rubbing; no wax operation necessary. Leaves a protective glossy film on aluminum and other metal surfaces. 2 lbs. per can.



| DESCRIPTION | PART NUMBER | PRICE EACH |
|-------------|-------------|------------|
| per can | 11-54 | 36.51 |

PPC ALUMINUM POLISH

Easy aluminum polish is a unique liquid formula that produces a "mirror like" shine in seconds on smooth aluminum, magnesium, stainless, brass, and nickel. Its ability to melt oxidation and simultaneously bring up the metal's true brilliance can't be matched by any other polish. Removes discoloration, water spots, without harsh abrasive, acids or ammonia. Protects with acrylic polymer barrier that resists hazing and water spotting. Polishes and protects clearcoat, also works on paint and plastics. Easier, faster, shinier than any other polish.



| DESCRIPTION | PART NUMBER | PRICE EACH |
|----------------------|-------------|------------|
| 8 oz. squeeze bottle | EAP | 10.99 |

WHEEL PAINT & PROTECTANT

Clear gloss polyurethane wheel paint is specially formulated to protect wheels from extreme temperatures, salt, brake dust, and rocks. Non-yellowing resists chipping, fading, cracking, and oxidation. Gives long-lasting protection and shine. No primer required. 16 oz. aerosol can.



| DESCRIPTION | PART NUMBER | PRICE EACH |
|-------------------------|-------------|------------|
| 16 oz spray can - clear | SP184 | 7.00 |

WHEELS & BRAKES



3600C



CWB10-20



CWB10-34



CWB10-35



CWB10-54



CWB10-55



MT-MC4



MT-MC4A



MT-MC5

| | | | | | | PORT | | | |
|---|------|-------|------|--------|------|-------------|-------|---------------------------------------|------------------------------|
| PITTS: Ports: 1/8 NPT 6Inline 80° Seal Repair Kit | .562 | 1.25 | .31 | 7.5-8" | Push | 1/8" NPT | 6 oz. | 3600C | NLA |
| CLEVELAND Ports: in line Fitting: 90° | .562 | 1.250 | .31 | 8.37 | Push | 7/16-20 | .50 | CWB10-19 | 247.50 |
| Ports: in line Fitting: none No rod clevis Seal Repair Kit | .562 | 1.250 | .31 | 7.50 | Push | 1/8-27 NPTF | .55 | CWB10-20 CWB199-505 | 227.50 8.26 |
| Reservoir - Cap = 3.0 cu/in. Fitting 90° from mounting hole.625 Seal Repair Kit | .625 | 1.200 | .36 | 8.00 | Push | 1/8-27NPTF | .60 | CWB10-34 CWB199-513 | 263.75 6.89 |
| Reservoir - Cap = 3.0 cu/in. Fitting in line to mounting hole.625 Seal Repair Kit | .625 | 1.200 | .36 | 8.00 | Push | 1/8-27NPTF | .60 | CWB10-35 CWB199-513 | 251.25 6.89 |
| Reservoir - Cap = 3.0 cu/in. Mounting hole = .190 dia Mounting Seal Repair Kit | .687 | 1.20 | .36 | 7.45 | Push | 1/8-27NPT | .52 | CWB10-45 CWB199-513 | 303.60 6.89 |
| Ports: in line Fittings: none Mounting: in line w/fitting Seal Repair Kit | .625 | 1.500 | .46 | 8.75 | Push | 1/8-27NPTF | .46 | CWB10-54 CWB199-516 | 167.99 3.84 |
| Ports: in line Fittings: none Mounting: 90°from fitting Seal Repair Kit | .625 | 1.500 | .46 | 8.75 | Push | 1/8-27NPTF | .46 | CWB10-55 CWB199-516 | 190.00 3.84 |
| MATCO: Ports: in line Mounting: in line or 90° Seal Repair Kit | .625 | 1.388 | .37 | 7.70 | Push | 1/8NTP | .410 | MT-MC4 MT-MC-RBD-4 | 99.45 5.99 |
| Ports: in line Mounting: in line or 90° Seal Repair Kit | .625 | 1.500 | .306 | 7.50 | Push | 1/8NTP | .375 | MT-MC4A MT-MC-RBD-4A | 93.00 5.49 |
| Reservoir Seal Repair Kit | .625 | 1.40 | .32 | 8.125 | Push | 1/8NTP | .366 | MT-MC5 MT-MC-RBD-5 | 93.00 13.50 |

WHEELS & BRAKES

BEARINGS

5/8" and 3/4" standard ball bearings for Azusa 5", 6" and 8" wheels.



| DESCRIPTION | PART NUMBER | PRICE EACH |
|---------------------|-------------|------------|
| 5/8" i.d. precision | AZ-8206 | 5.05 |
| 3/4" i.d. standard | AZ-8201 | 1.94 |

3/4" BORE AZUSA 4-1/2" BRAKE ASSEMBLY

Round style assembly with 3/4" bore for use on Azusa 5" & 6" wheels. 4-1/2" brakes have long actuating arm, 3/4" mounting hole and premium bonded lining. Weight: 1.054 lb.



| DESCRIPTION | PART NUMBER | PRICE EACH |
|--------------------------------|-------------|------------|
| Round style assembly 3/4" bore | AZ-2272A | 27.95 |

5/8" BORE AZUSA BRAKE ASSEMBLY

Use on 5" and 6" Azusa wheels with 5/8" bores. 4-1/2" brakes have long actuating arm, 5/8" mounting hole and premium bonded lining.

Anchor style has backing plate - built in anchor with two cable mounting ears. Weight 1.520 lbs. **Round style** has round aluminum backing plate. Weight 1.054 lbs. Note: AZ-1057 azusalite wheel requires the AZ2259A platform listed below.

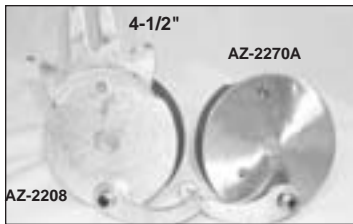

| DESCRIPTION | PART NUMBER | PRICE EACH |
|---------------------------------|-------------|------------|
| Anchor style assembly 5/8" bore | AZ-2208 | 27.95 |
| Round style assembly 5/8" bore | AZ-2270 | NLA |

PLATFORM FOR AZ1057 WHEEL

Used only on the AZ-1057 azusalite wheel. Weight .320 lbs.



| DESCRIPTION | PART NUMBER | PRICE EACH |
|----------------------------|-------------|------------|
| Platform for AZ-1057 wheel | AZ-2259A | 8.74 |

BRAKE REPLACEMENT PARTS

Replacement parts for Azusa brake assemblies
AZ-2208, AZ-2270A and AZ-2272A



| DESCRIPTION | PART NUMBER | PRICE EACH |
|-------------------------------|-------------|------------|
| Lined shoes - 1 pair per side | AZ-2260 | 13.55 |
| Brake arm | AZ-2261 | NLA |
| ACTUATOR ARM | AZ-2263 | 1.90 |
| Cam | AZ-8235 | 5.80 |
| Spring | AZ-2264 | 1.50 |

BRAKE DRUMS - AZUSA

Azusa drums are machined for the concentricity needed to make even contact. The 1/4" - 4 hole pattern and the 5/16" - 3 hole pattern are on a 3.75" bolt hole circle. May be used on either 5" or 6" wheels. Weight .684 lb.



| DESCRIPTION | PART NUMBER | PRICE EA |
|-----------------------|-------------|----------|
| 4-1/2" drum no flange | AZ-2211 | 8.06 |

AZUSA BRAKES - AZ-1157 WHEEL

5" for use on 8" Azusa wheels AZ-1175 only. Have a sturdy actuating arm which allows for 8 positions, bonded 7/8" lining, 5/8" mounting hole.

BACKING PLATE - round cast aluminum weight .960 lbs.
RENEWAL PARTS - used in conjunction with the 5" brakes.

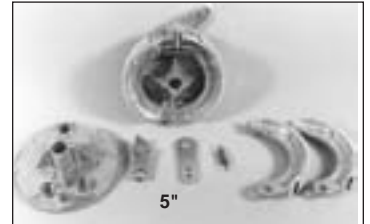

| DESCRIPTION - 8" WHEELS | PART NUMBER | PRICE EACH |
|------------------------------------|-------------|------------|
| Round style asby - Weight 1.090 lb | AZ-2530 | 28.95 |
| Lined shoes - 1 pr p/side | AZ-2538 | 13.75 |
| Brake arm | AZ-2537 | 5.15 |
| Spring | AZ-2539 | 1.35 |
| Cam | AZ-2533 | 7.71 |

AZ-2530 BRAKE DRUM

For 5" without flange 3-1/4" bolt circle. Used only on the AZ-2530 assembly for use on the AZ-1157 wheel. Weight 1.240 lb.



| DESCRIPTION | PART NUMBER | PRICE EACH |
|-------------------------|-------------|------------|
| Drum - for AZ-2530 only | AZ-2542 | 11.95 |

BLEEDER-ADAPTER

Bleeder screws into adapter, adapter screws into wheel cylinder. Fits all standard brake systems. 1/8" male NPT. Sold in pairs.



| DESCRIPTION | PART NUMBER | PRICE EACH |
|---------------|-------------|------------|
| Brake bleeder | A-1480 | 12.50 |

CABLE STOPS

Use for cable ends on mechanical actuated brakes.

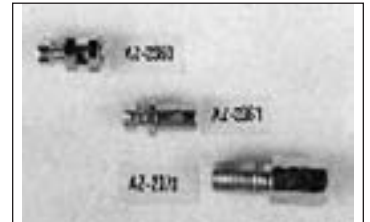

| DESCRIPTION | PART NUMBER | PRICE EACH |
|--------------------------------|-------------|------------|
| Cable stop | AZ-2360 | 0.75 |
| Wire swivel 8-32 female thread | AZ-2361 | 0.85 |
| Retainer w/5-16-24 threads | AZ-2372 | 1.15 |

WHEELS & BRAKES

BRAKE FLUID

Red petroleum for hydraulic systems with synthetic rubber seals.

HAZARD



| DESCRIPTION | PART NUMBER | PRICE EACH |
|-------------|-------------|------------|
| Pint | MILH5606-PT | 4.90 |
| Quart | MILH5606-QT | 7.34 |
| Gallon | MILH5606-G | 25.09 |

PARKING BRAKE VALVE

Lightweight, easy in line installation makes it ideal for homebuilders who desire this important option in their aircraft. Overall dimensions of this product are 2-1/2" x 2-1/4" x 3/4". This valve features high quality components including industrial springs, Matco o-rings for a leakproof seal, standard size fittings utilizing a tapered pipe thread which attaches easily to most other fittings. The body is black anodized aluminum for corrosion resistance and long life. The lever arm of the cam shaft is nickel plated to ensure hardness and smooth operating efficiency within a 45° actuating range. Weight 5 oz.



| DESCRIPTION | PART NUMBER | PRICE EACH |
|---------------|-------------|------------|
| Parking valve | MT-PV-1 | 129.00 |

CLEVELAND PARKING VALVE

Maximum operating pressure- 1,500 psi, use MIL-H-5606 brake fluid. Maximum weight, .50 lb. Has 7/16-20 UNF-3A outlet ports, with 1" spacing. Supplied with MS20822-4D aluminum fitting. 3/4" x 1-1/2" x 2".



| DESCRIPTION | PART NUMBER | PRICE EACH |
|---------------|-------------|------------|
| Parking valve | CWB60-5 | 269.75 |

RUDDER PEDALS

Professionally made aluminum pedals as used in production aircraft. 5" wide x 6" long. Weight 3/4-lb. ea. Sold in pairs



| DESCRIPTION | PART NUMBER | PRICE EACH |
|----------------------|-------------|------------|
| Rudder pedals (PAIR) | A-1260 | 47.71 |

STEEL PEDAL SET

An inexpensive, yet rugged pedal set (left & right) with built-in stops. Four 1/4" predrilled holes allow adjustable actuating rod connection. Each includes a 5/16-18x1.75" mounting bolt. 6-1/2" total length. Weight each 7oz.



| DESCRIPTION | PART NUMBER | PRICE P/SET |
|-------------|-------------|-------------|
| Pedal set | AZ-PEDALS | 10.89 |

AZUSA AXLES

These axles are especially designed for use with Azusa wheels and brakes.

The bolt on axles are manufactured from high quality Grade 8 steel to provide reliable service. Hole spacing is standard 2 x 1-1/8". Models are available for wheels with or without brake assemblies. Brake backing plate mounts easily to attachment plate using AN4C-5A stainless bolts and MS21044C4 stainless nuts. Axles and spacers are available for all stock Azusa wheels. **See individual Azusa wheel descriptions for appropriate axle and spacer model numbers to order.**



| WHEEL NUMBER | SIZE WHEEL | AXLE SIZE | AXLE NUMBER NO BRAKES | AXLE NUMBER WITH BRAKES | PRICE EACH |
|--------------|------------|-----------|-----------------------|-------------------------|------------|
| AZ-1137 | 5" | 3/4" | AZ-3410 | AZ-347 | NLA |
| AZ-1105 | 6" | 3/4" | AZ-344 | AZ-348 | NLA |
| AZ-1127 | 6" | 3/4" | AZ-344 | AZ-348 | NLA |
| AZ-1144 | 5" | 5/8" | AZ-581 | AZ-585 | NLA |
| AZ-1057 | 5" | 5/8" | AZ-582 | | 24.00 |
| AZ-1072 | 6" | 5/8" | | AZ-583 | 28.50 |
| AZ-1175 | 8" | 5/8" | AZ-581 | AZ-585 | NLA |

AXLES

Bolt-on type machined from 2024-T3 aluminum with gold or black colored chemical coating to air in corrosion resistance. Weld on type for use with welded type gear. Made of 4130 steel tubing threaded on one end for use with round nuts. AX5 hole spacing 1-3/8 x 1-3/8, AX6 hole spacing 2 x 1-1/8



| WHEEL | THREAD | LENGTH | PART NUMBER | PRICE EACH |
|---------|------------|--------|-------------|------------|
| 500 x 5 | 1-1/4 x 16 | 5-3/4" | AX5 | 45.00 |
| 600 x 6 | 1-1/2 x 16 | 6-1/4" | AX6 | 59.19 |

WELD ON:

| | | | | |
|---------|------------|-----|------------|-------|
| 500 x 5 | 1-1/4 x 12 | 12" | AX1-1/4x12 | 27.82 |
| 600 x 6 | 1-1/2 x 16 | 12" | AX1-1/2x12 | 27.82 |

NUTS & SPACERS

NUTS: Castle or round made of mild steel.

AX1-1/4 uses MS24665-377 cotter pin, AX1-1/2 uses MS24665-364.

SPACERS: For use with 500x5 or AX5 axles, 2 ea #A484 required per axle for Cleveland. Cleveland kits CWB199-153 & CWB199-156 require one 7/16" spacer and one 1/4" spacer per axle.



| NUT TYPE | THREAD | AXLE TYPE | PART NUMBER | PRICE EACH |
|----------|----------|------------|-------------|------------|
| Castle | 1-1/4x16 | AX5 | MS21025-20 | 10.40 |
| Castle | 1-1/2x16 | AX6 | MS21025-24 | 10.65 |
| Round | 1-1/4x12 | AX1-1/4x12 | AXN1-1/4x12 | 7.55 |
| Round | 1-1/2x16 | AX1-1/2x16 | AXN1-1/2x16 | 7.90 |

SPACER

| | | |
|------------------------------------|-----------|------|
| 1/4" spacer for 1-1/4" axles only | A484 | 5.50 |
| 7/16" spacer for 1-1/4" axles only | A484-4375 | 5.50 |
| 1/4" spacer for 1-1/2" axles only | AS200-110 | NLA |

WHEELS & BRAKES

AXLE SHIMS

2024-T3 shims available for both 500 x 5 and 600 x 6 axles. Camber adjustment shims adjust vertical alignment: Toe-in/out re-alignment shims insure that tires track true for improved ground handling.

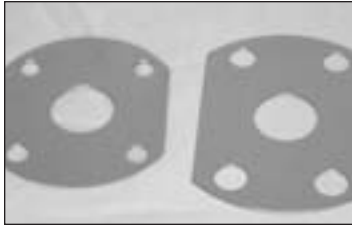

| CAMBER | CORRECTION | PART NUMBER | PRICE EACH |
|--------------------|------------|-------------|------------|
| 500 x 5 | 1/2 | C500-2 | 24.53 |
| 500 x 5 | 1 | C500-4 | 24.53 |
| 500 x 5 | 2 | C500-8 | 24.53 |
| 600 x 6 | 1/2 | C600-2 | 27.59 |
| 600 x 6 | 1 | C600-4 | 27.58 |
| 600 x 6 | 2 | C600-8 | 24.53 |
| Toe-In/Out - 500x5 | 1/4 | T500-1 | 24.53 |
| Toe-In/Out - 500x5 | 1/2 | T500-2 | 24.53 |
| Toe-In/Out - 500x5 | 3/4 | T500-3 | 24.53 |
| Toe-In/Out - 600x6 | 1/4 | T600-1 | 25.53 |
| Toe-In/Out - 600x6 | 1/2 | T600-2 | 27.59 |
| Toe-In/Out - 600x6 | 3/4 | T600-3 | 26.53 |

How to Select Proper Axle Shim

1. Support the aircraft in level flying altitude. 2. Chalkline the center line of the aircraft onto the floor. Do this by connecting a mark on the floor from directly beneath the center of the firewall (use a plumb-bob) and from directly beneath the center of the tail (with a plumb-bob). 3. Place a 36" straight edge against the outside of the tire. It should be parallel with the floor and approximately centered on the wheel. 4. Make a mark on the floor directly beneath each end of the 36" straight edge. Use a plumb-bob or square for this. 5. Measure and record distances D-1 and D-2. 6. Calculate toe-in/out which is the difference between D-1 and D-2. This measurement changes by 0.157" for each 1/4 inch.

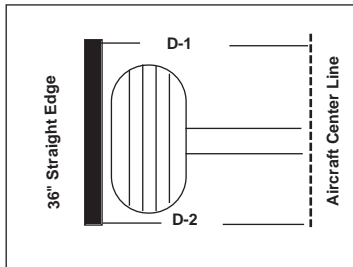

STRUT VALVE

These high pressure strut valves are used in applications up to 5000 psi. Made of corrosion resistant steel.



| DESCRIPTION | PART NUMBER | PRICE EACH |
|-------------|-------------|------------|
| Strut valve | MS28889-2 | 16.34 |

SHOCK CORD RINGS

Heavy duty, higher test rings. Spec MIL-C5615B, Type II

1080HD: Piper-PA-16,18,18-"95"18-A, 20 (1952 & up),22,25.

1280HD:Piper J-3 SN827 up, PA-11,12,14,17,18(S/N18-3013),18-"135",18

1080:PA22-105, Stolp Starduster 9010HD: Taylorcraft, BC12D, BC12-85, BC19, F1



| CORD O.D. | RING I.D. | TEST *LBS. | PART NUMBER | PRICE EACH |
|-----------|-----------|------------|-------------|------------|
| 5/8" | 8" | 825 | SR1080 | 30.00 |
| 5/8" | 8" | 900 | SR1080HD | 18.00 |
| 3/4" | 8" | 950 | SR1280HD | 20.00 |
| 9/16" | 10" | 475 | SR9010HD | 22.00 |

SHOCK CORD & FASTENERS

Double covered nylon shock cord has a multi-strand live rubber core protected with an abrasion resistant braided nylon fibre jacket. It is rot resistant with long-life stretch and elasticity **TO ASSEMBLE:** Insert cord through small end of terminal fastener.



Tie knot and crimp locking ring behind knot. Trim end and pull knot inside terminal. Ends of cord may be dipped in rubber cement or lacquer to seal ends. MIL-C-5651D - Type 1.

| DESCRIPTION | PART NUMBER | PRICE EACH |
|-------------|-------------|------------|
| 1/4" cord | SC-250 | 0.92 |
| 3/8" cord | SC-375 | 1.69 |
| 1/2" cord | SC-500 | 2.13 |

| TERMINAL SIZE | FASTENER PART NO. | LOCKING PRICE EACH | RING PART NO. | PRICE EACH |
|---------------|-------------------|--------------------|---------------|------------|
| 1/4 | H-250 | 0.85 | H-251 | 0.25 |
| 3/8 | H-375 | 0.90 | H-376 | 0.35 |
| 1/2 | H-500 | 1.50 | H-501 | 0.64 |

WHEELS & BRAKES

| AIRCRAFT Old Make & Model | Amount Cleveland Number | New Reqrd | Cleveland Number |
|--|-------------------------------|--------------|---------------------|
| AEROTEK Pitts S-1, S-2A | 66-2 | 2 | 66-106 |
| BEECH Musketeer | 66-55 | 2 | 66-105 |
| Sierra Sport Sundowner B-19, C-23, 24R | 66-55 | 2 | 66-105 |
| Debonair CD-1 thru CD-387 | 66-4 | 2 | 66-111 |
| Debonair B-33 | 66-2 | 2 | 66-106 |
| BELLANCA Citabria, Champ | 66-2 | 2 | 66-106 |
| Scout | 66-3 | 1 | 66-106 |
| Decathlon, Scout 8GCBC | 66-2 | 2 | 66-106 |
| Viking, Aries 250 | 66-55 | 2 | 66-105 |
| Skipper | 66-71 | 2 | 66-112 |
| CESSNA 150A, B,C,D,E | 66-2 | 2 | 66-106 |
| 150F, G, J, K, 152, F-152, FA-152 | 66-55 | 2 | 66-106 |
| Skyhawk 172, Cardinal 177 All | 66-55 | 2 | 66-105 |
| Skywagon 180 | 66-55 | 4 | 66-105 |
| Skylane 182 H, J, K, L, M, N | 66-55 | 2 | 66-105 |
| 185A, B | 66-2 | 2 | 66-106 |
| 185C, D,E | 66-55 | 2 | 66-105 |
| 185 with crosswind gear | 66-2 | 2 | 66-106 |
| AG Wagon | 66-55 | 4 | 66-105 |
| Stationair-6, 205, 205A | 66-2 | 2 | 66-106 |
| Stationair-6 205, 205A (s/n 205-0481 & up | 66-55 | 4 | 66-105 |
| 206, U206A,D,E & Turbo models | 66-55 | 4 | 66-105 |
| 207, T207 | 66-55 | 4 | 66-105 |
| 21-C | 66-4 | 2 | 66-111 |
| 210, P210, T210, 210N, P210N | 66-55 | 4 | 66-105 |
| 305A, B, C, D,E,F | 66-55 | 4 | 66-105 |
| 310, 335 | 66-33 | 6 | 66-33 |
| Skymaster336 | 77-2 | 2 | 66-106 |
| 337, T337, 337B, C, D, E, T337B, C, D, E | 66-55 | 4 | 66-105 |
| All Cessnas using Cessna/McCauley Brakes | B-30026 | 2 | |
| GRUMMAN AA-1, A,B< AA-5AA-5A. AA-5B, Tiger, TR-2 | 66-55 | 2 | 66-105 |
| Ag-Cat | 66-3 | 1 | 66-106 |
| | 66-56 | 2 | 66-106 |
| G-154 | 66-2 | 2 | 66-106 |

| AIRCRAFT Make & Model | Old Cleveland Number | Amount Reqrd | New Cleveland Number |
|--|----------------------------|-----------------|----------------------------|
| MAULE Jetasen/Rocket, Lunar/Rocket | 66-55 | 2 | 66-105 |
| MOONEY Most M20, A,B, D, E | 66-4 | 2 | 66-111 |
| PIPER Colt PA 22-108 | 66-2 | 2 | 66-106 |
| Apache PA-23, 150, 160 | 66-2 | 2 | 66-106 |
| | 66-56 | 2 | 66-106 |
| Apache/Aztec PA-23-235, 250 Series | 66-2 | 4 | 66-106 |
| | 66-3 | 4 | 66-106 |
| Comanche PA-24-180, 250, 260 | 66-2 | 2 | 66-106 |
| Pawnee C PA-25 | 66-2 | 2 | 66-106 |
| Cherokee/Cruiser PA-28-140 | 66-2 | 2 | 66-106 |
| PA-28-140 s/n 28-20521 & up | 66-55 | 2 | 66-105 |
| Cherokee PA-28-150 | 66-2 | 2 | 66-106 |
| Cherokee PA-28-105 s/n 28-1761 & up | 66-55 | 2 | 66-105 |
| Cherokee Warrior PA-28-151 | 66-55 | 2 | 66-105 |
| Cherokee PA-28-160 | 66-2 | 2 | 66-106 |
| Cherokee/Warrior II PA-28-161 | 66-55 | 2 | 66-105 |
| Cherokee/Archer PA-28-180 | 66-2 | 2 | 66-106 |
| Cherokee/Archer PA-28-160 | 66-55 | 2 | 66-105 |
| Cherokee/Pathfinder PA-28-200 | 66-2 | 2 | 66-106 |
| PA-2R-180 s/n 28R-7130006 U up | 66-55 | 2 | 66-105 |
| PA-28-200 s/n 28R-7135110 U up | 66-55 | 2 | 66-105 |
| PA-28R-201T, 20a, PA28RT-201, 201T | 66-55 | 2 | 66-105 |
| Early PA-28-235 | 66-56 | 2 | 66-105 |
| Navajo B, PA31-300, 310 Turbo Navajo | 66-33 | 6 | 66-33 |
| Chieftain, PA-31-350 | 66-33 | 6 | 66-33 |
| Cherokee/ Six-260 PA-32-260 | 66-55 | 4 | 66-105 |
| PA-32-300 s/n 32-40000 thru 7200029 | 66-55 | 4 | 66-105 |
| PA-32R-300 32RT-300 | 66-55 | 4 | 66-105 |
| PA-38-112 | 66-72 | 2 | 66-112 |
| PA-39, PA-39-1 U up | 66-3 | 1 | 66-106 |
| PA-44-180 | 66-55 | 4 | 66-105 |
| TAYLORCRAFT Sportsman 100 | 66-55 | 2 | 66-105 |

BRAKE PADS

Check chart for proper application.
Cleveland or Rapco.

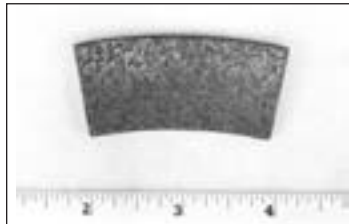

BRAKE PADS

Cleveland kits CWB-102, 102C, 103, 103C and 156 as referenced by chart.
Available in Cleveland or Rapco.

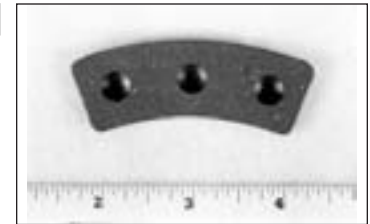

| DESCRIPTION | PART NUMBER | PRICE EACH |
|-----------------------|-----------------|--------------|
| Brake pad - Rapco | RA66-33 | 7.49 |
| Brake pad - Cleveland | CWB66-33 | 10.29 |

| DESCRIPTION | PART NUMBER | PRICE EACH |
|-----------------------|------------------|--------------|
| Brake pad - Rapco | RA66-106 | 7.49 |
| Brake pad - Cleveland | CWB66-106 | 12.61 |

BRAKE PADS

Cleveland kits CWB-105, 105C, 133X, 152 and as referenced by chart. Available in Cleveland or Rapco.

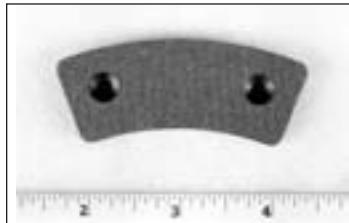

BRAKE PAD

As referenced by chart. Available in Cleveland or Rapco

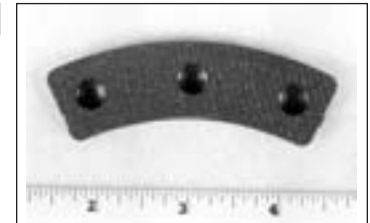

| DESCRIPTION | PART NUMBER | PRICE EACH |
|-----------------------|------------------|--------------|
| Brake pad - Rapco | RA66-105 | 7.86 |
| Brake pad - Cleveland | CWB66-105 | 12.45 |

| DESCRIPTION | PART NUMBER | PRICE EACH |
|-----------------------|------------------|--------------|
| Brake pad - Rapco | RA66-111 | 9.00 |
| Brake pad - Cleveland | CWB66-111 | 16.91 |

WHEELS & BRAKES

BRAKE PADS

Cleveland kits CWB-104, 104C and as referenced by chart.

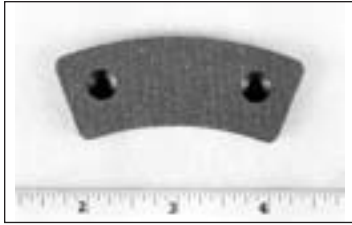

| DESCRIPTION | PART NUMBER | PRICE EACH |
|-------------|-------------|------------|
| Brake pad | CWB66-112 | 18.40 |

RIVETS

Fit all Cleveland linings. Check lining for rivets required. 1/4" long, 1/8" hole diameter, 5/16" head.



| DESCRIPTION | PART NUMBER | PRICE EACH |
|-------------|-------------|------------|
| Rivets | CWB105-2 | 0.22 |

RIVETS

Needed to install linings on Matco brakes. Longer length than Cleveland rivets. 3/8" long, 1/8" hole diameter, 5/16" head.

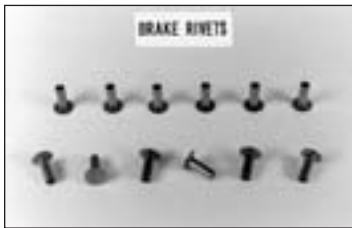

| DESCRIPTION | PART NUMBER | PRICE EACH |
|-------------|-------------|------------|
| Rivets | MT-4/6 | 0.24 |

BRAKE RIVET TOOL

Reline aircraft brakes and general riveting with this machine steel tool. Comes complete with holding frame, anvil, and punch for removing and clinching rivets. Also available with threaded driver.



| DESCRIPTION | PART NUMBER | PRICE EACH |
|-------------|-------------|------------|
| Rivet tool | ATSW-403 | 20.33 |

BRAKE RIVET TOOL

Similar to ATSW-403 but with a threaded driver, NOT for use with hard steel, rivets or pins.



| DESCRIPTION | PART NUMBER | PRICE EACH |
|-------------|-------------|------------|
| Threaded | RA825 | 35.00 |

3.5" NON-PNEUMATIC TAILWHEEL

No grease zerk, 1-1/2" wide, bore 3/8". Weight .839 lbs. Rated for up to 200 lbs.



| DESCRIPTION | PART NUMBER | PRICE EACH |
|-------------|-------------|------------|
| 3.5" wheel | TWNP-3.5 | 25.00 |

4" NON-PNEUMATIC TAILWHEEL

Neither tailwheel has grease zerk. 3/8" bore is 1-11/16" wide, rated for up to 225 lbs, weight 1.079 as used on Dragonfly. 5/8" bore tailwheel is 1-1/2" wide, rated to 225 lbs.



| DESCRIPTION | PART NUMBER | PRICE EACH |
|----------------------|-------------|------------|
| 3/8" bore - 4" wheel | TWNP-4 | 25.00 |
| 5/8" bore - 4" wheel | TWNP-4A | 29.38 |

5" NON-PNEUMATIC TAILWHEEL

1-11/16 wide, 5/8" bore, weight 1.355. Rated for up to 270 lbs.



| DESCRIPTION | PART NUMBER | PRICE EACH |
|-------------|-------------|------------|
| 5" wheel | TWNP-5 | 30.00 |

6" NON-PNEUMATIC TAILWHEEL

1-3/4" wide, bore 3/8". Weight 1.883 lbs. As used in PDQ. Rated up to 325 lbs.



| DESCRIPTION | PART NUMBER | PRICE EACH |
|-------------|-------------|------------|
| 6" wheel | TWPD-66 | 27.00 |

WHEELS & BRAKES

6" NON-PNEUMATIC TAILWHEEL

2.250" wide, bore 5/8". Weight 2.754 lbs. Rated up to 460 lbs.

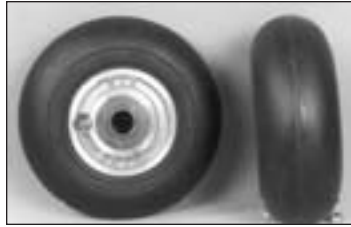

| DESCRIPTION | PART NUMBER | PRICE EACH |
|-------------|-------------|------------|
| 6" wheel | TWNP-6 | 35.00 |

8" PNEUMATIC TAILWHEEL

1/2" bore. Weight 3.70 lbs. Includes tire 2.80 x 2.50 x 4 ply and tube. As in Maule kits TWS1-4P8A, TWS1-2P8A, TWS3-4P8A tailwheels.



| DESCRIPTION | PART NUMBER | PRICE EACH |
|----------------------|-------------|------------|
| 8" Wheel, tire, tube | TW-38 | 148.90 |

MATCO TAILWHEEL 6"

Fits 1-1/4 or 1-1/2" full swivel locking. 6" solid rubber weighs 4.7 lbs. Rated up to 450 lbs.



| DESCRIPTION | PART NUMBER | PRICE EACH |
|-------------|-------------|------------|
| 6" assembly | MT-TWA | 158.02 |

MATCO TAILWHEEL 8"

Fits 1-1/4 or 1-1/2" full swivel locking. 8" pneumatic weighs 7.0 lbs.



| DESCRIPTION | PART NUMBER | PRICE EACH |
|-------------|-------------|------------|
| 8" assembly | MT-TWA-1 | 220.00 |
| 4" tire | TR100-045 | 47.76 |
| 4" tube | TB100-045 | 11.34 |

FULL SWIVEL TAILWHEEL

6" Locks in steerable mode when aircraft is moved forward. Releases to full swivel when pushed sideways or backwards, or when maneuvering on the ground using brakes. Removable shim allows use with either 1-1/4" or 1-1/2" flat springs. Weight 4 lbs 9 oz.



| DESCRIPTION | PART NUMBER | PRICE EACH |
|--------------------------|-------------|------------|
| 6" Full swivel tailwheel | 6116 | 289.38 |

TWSA-SFSA SERIES ASSEMBLY

6.50 x 2.5 solid tire, constructed of material same as SFS-P8A unit. Steerable with full swiveling unit, beyond full rudder range. New improved single arm shimmy-free fork. Assembles to fit two different leaf spring sizes. Maule SFSA unit. Replacement parts on following pages.



| SPRING SIZE | PART NUMBER | PRICE EACH |
|-------------|-------------|------------|
| 1-1/4" | TWSA-1-4 | 264.28 |
| 1-1/2" | TWSA-1-2 | 257.78 |

TWSA-SFS-P8A SERIES ASSEMBLY

Equipped with shimmy-free fork and 8 x 300-4 tire and tube. Fully steerable beyond full rudder range. All working parts are highly heat treated assemblies to fit two different leaf sizes. Replacement parts listed: Replacement parts on following pages.



| SPRING SIZE | PART NUMBER | PRICE EACH |
|-------------|-------------|------------|
| 1-1/4" | TWS1-4P8A | 285.05 |
| 1-1/2" | TWS1-2P8A | 284.00 |

MODEL P8B TAILWHEEL ASSEMBLY

Equipped with 8" pneumatic tire, present the industry with a thoroughly modern solution to airplane landing, taxiing and handling problems. Construction features: Steerable full-swiveling, steerable full rudder range, new improved single arm shimmy-free fork with friction washer in bottom, extra heavy duty, all bearings in wheel & caster are Timkin tapered roller bearings, aluminum hub and caster, 8 x 3:00 - 4 tire and tube, all working parts highly heat-treated. Replacement parts on following pages.



| DESCRIPTION | PART NUMBER | PRICE EACH |
|--------------------|-------------|------------|
| Fits 1-1/4" spring | TWS1-4P8B | 387.23 |
| Fits 1-1/2" spring | TWS1-2P8B | 369.60 |
| Fits 1-3/4" spring | TWS3-4P8B | 389.00 |

WHEELS & BRAKES

REPLACEMENT PARTS FOR TWSA SOLID TAILWHEEL

Fits TWSA-SFSA assemblies. Dash number corresponds with number indicating part.

| DESCRIPTION | PART NUMBER | PRICE EACH |
|-------------------------|-------------|------------|
| Zerk | TW-A14 | 1.89 |
| Bearing | TW-A15 | 10.64 |
| Screw | TW-A18 | 0.42 |
| Axle w/circlip | TW-5 | 20.15 |
| Axle circlip ring | TW-6 | 1.90 |
| Cam | TW-10 | 8.00 |
| Lock coverplate | TW-12 | 4.85 |
| Lock pin | TW-13AB | 25.00 |
| Steering arm spring | TW-14 | 4.50 |
| Steering arm asby | TW-15A | 45.00 |
| Bracket 1-1/4" | TW-22A114 | 68.00 |
| Tire assy w/bearing | TW-23A | 82.00 |
| Felt seal | TW-26 | 2.60 |
| Hub cap w/zerk & screws | TW-27 | 15.92 |
| Washer | TW-28 | 2.25 |
| Lock ring | TW-57A | 14.16 |
| Oilite bearing | TW-59A | 13.24 |
| Lock ring pin | TW-60AB | 2.60 |
| Fork | TW-61A | 65.08 |
| Cover cap | TW-63A | 5.67 |
| Retainer washer | TW-6 | 1.90 |

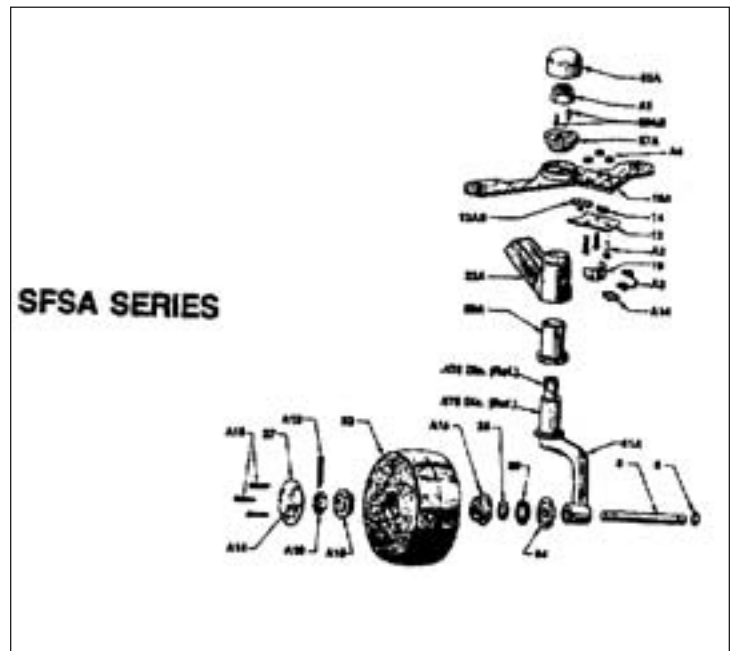

REPLACEMENT PARTS FOR SFS-P8A ASSEMBLY

Fits TWSA-SFS-P8A assemblies. Dash number corresponds with number indicating part.

| DESCRIPTION | PART NUMBER | PRICE EACH |
|-----------------------|-------------|------------|
| Washer | TW-A6 | 1.75 |
| Bearing | TW-A7 | 29.33 |
| Tire: TW-A8 | TR100-045 | 47.76 |
| Tube: TW-A9 | TB100-045 | 11.34 |
| Zerk | TW-A14 | 1.89 |
| Axle w/circlip | TW-5 | 20.15 |
| Axle circlip ring | TW-6 | 1.90 |
| Cam | TW-10 | 8.00 |
| Lock cover plate | TW-12 | 4.85 |
| Lock pin | TW-13AB | 25.00 |
| Steering arm spring | TW-14 | 4.50 |
| Steering arm asby | TW-15A | 45.00 |
| Bracket 1-1/4" | TW-22A114 | 68.00 |
| Bracket 1-1/2" | TW-22A112 | 68.00 |
| Inside hub w/bearings | TW-30 | 96.67 |
| Outside hub | TW-31 | 25.19 |
| Hub cap | TW-32 | 14.71 |
| Hub cap circlip ring | TW-33 | 7.50 |
| Lock ring | TW-57A | 14.16 |
| Fork | TW-58A | 47.57 |
| Oilite bearing | TW-59A | 13.24 |
| Lock ring pin | TW-60AB | 2.60 |
| Cover cap | TW-63A | 5.67 |

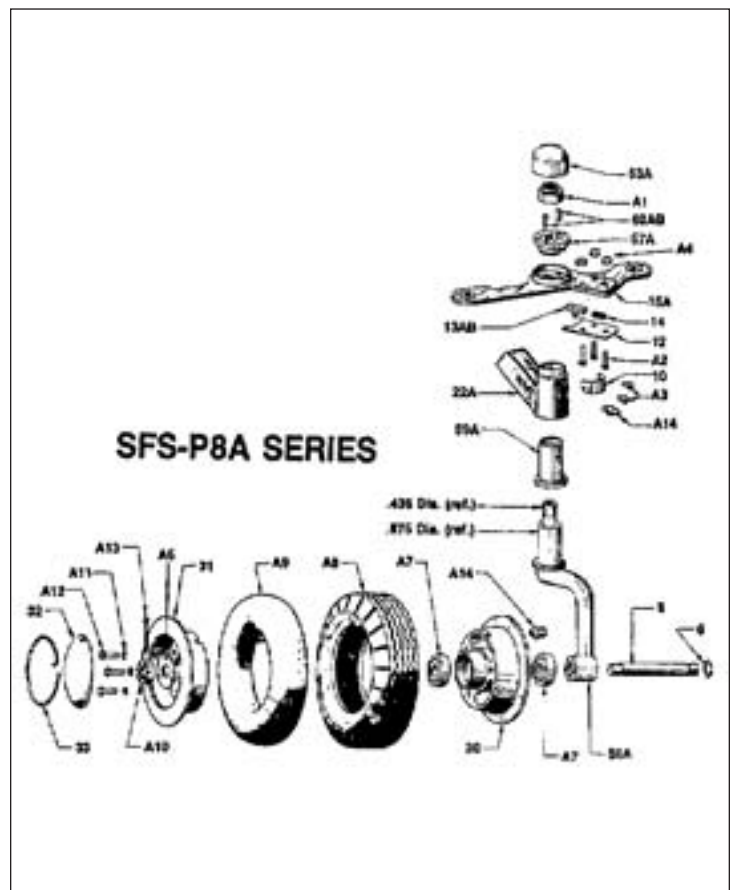

WHEELS & BRAKES

REPLACEMENT PARTS SFS-P8B SERIES

Number corresponds with number indicating part.

| DESCRIPTION | PART NUMBER | PRICE EACH |
|-----------------------|-------------|------------|
| Tire : TW-A8 | TR100-045 | 47.76 |
| Tube: TW-A9 | TB100-045 | 11.34 |
| Zerk | TW-A14 | 1.89 |
| Axle w/circlip | TW-5 | 20.15 |
| Axles circlip ring | TW-6 | 1.90 |
| Lock cover plate | TW-12 | 4.85 |
| Lock pin | TW-13AB | 25.00 |
| Steering arm spring | TW-14 | 4.50 |
| Inside hub w/bearings | TW-30 | 96.67 |
| Outside hub | TW-31 | 25.19 |
| Hub cap | TW-32 | 14.71 |
| Hub cap circlip ring | TW-33 | 7.50 |
| Lock ring pin | TW-60AB | 2.60 |
| Steering arm asby | TW-66B | 71.38 |
| Fork | TW-69B | 87.26 |
| Friction ring | TW-72B-3 | 10.08 |
| Friction washer | TW-72B-4 | 6.75 |
| Cover cap | TW-74B | 7.00 |
| Spring | TW-76B | 7.88 |
| Shield | TW-77B | 2.75 |
| Small felt seal | TW-78B-1 | 2.35 |
| Large felt seal | TW-78B-2 | 2.40 |

SFS-P8B

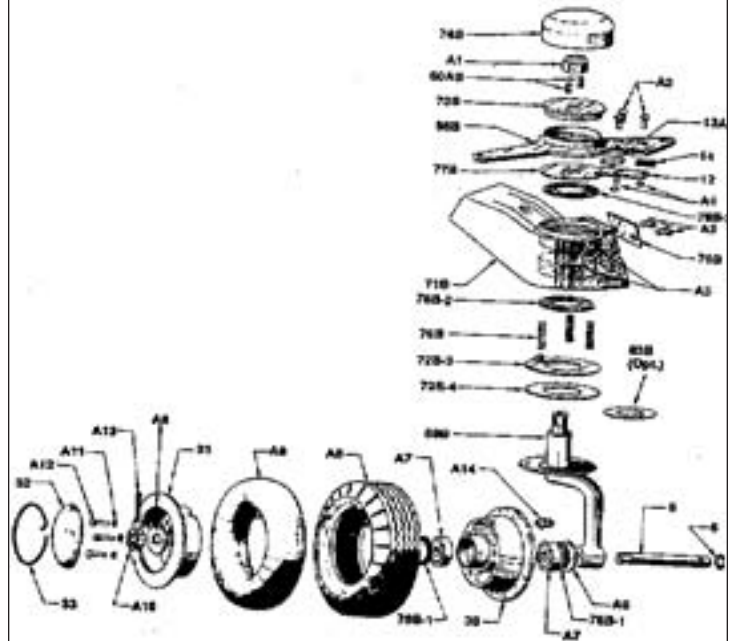

REPLACEMENT PARTS FOR OBSOLETE TW UNITS

Dash number corresponds with number indicating part.

| DESCRIPTION | PART NUMBER | PRICE EACH |
|---------------------|-------------|------------|
| Oilite bearing | TW-7 | 13.24 |
| Cam | TW-10 | 8.00 |
| Lock cover plate | TW-12 | 4.85 |
| Lock pin | TW-13 | 15.00 |
| Steering arm spring | TW-14 | 4.50 |
| Steering arm asby | TW-15 | 45.00 |
| Lock ring | TW-16 | 15.21 |
| Lock ring pin | TW-17 | 2.90 |
| Cover cap | TW-18 | 6.99 |
| Bracket 1-1/4" | TW-22114 | 68.00 |
| Bracket 1-1/2" | TW-22112 | 68.00 |

Remainder same as SFS unit

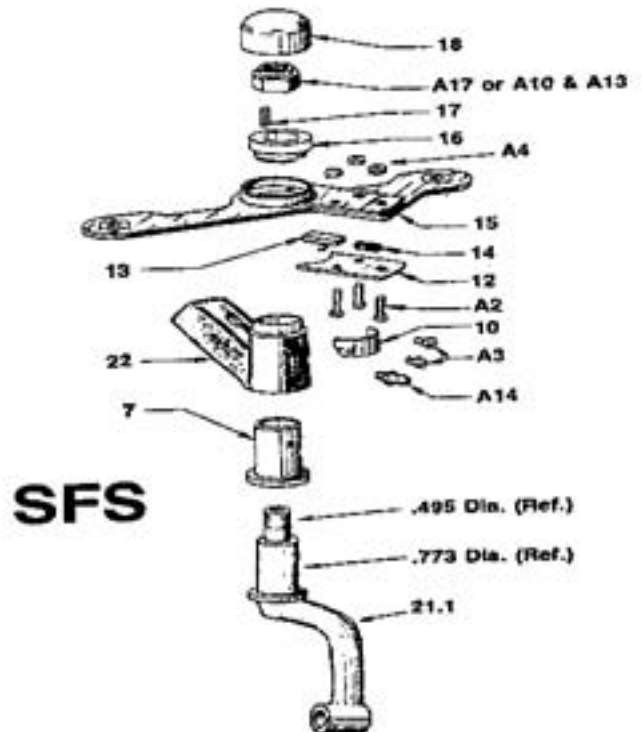

WHEELS & BRAKES

OBSOLETE SFS-P8A

Remainder same as SFS-P8A

| DESCRIPTION | PART NUMBER | PRICE EACH |
|-----------------------|-------------|------------|
| Zerk | TW-A14 | 1.89 |
| Oilite bearing | TW-7 | 13.24 |
| Cam | TW-10 | 8.00 |
| Lock Cover plate | TW-12 | 4.85 |
| Lock pin | TW-13 | 15.00 |
| Steering arm spring | TW-14 | 4.50 |
| Steering arm assembly | TW-15 | 45.00 |
| Lock ring | TW-16 | 15.21 |
| Lock ring pin | TW-17 | 2.90 |
| Cover cap | TW-18 | 6.99 |
| Bracket 1-1/4" | TW-22A114 | 68.00 |

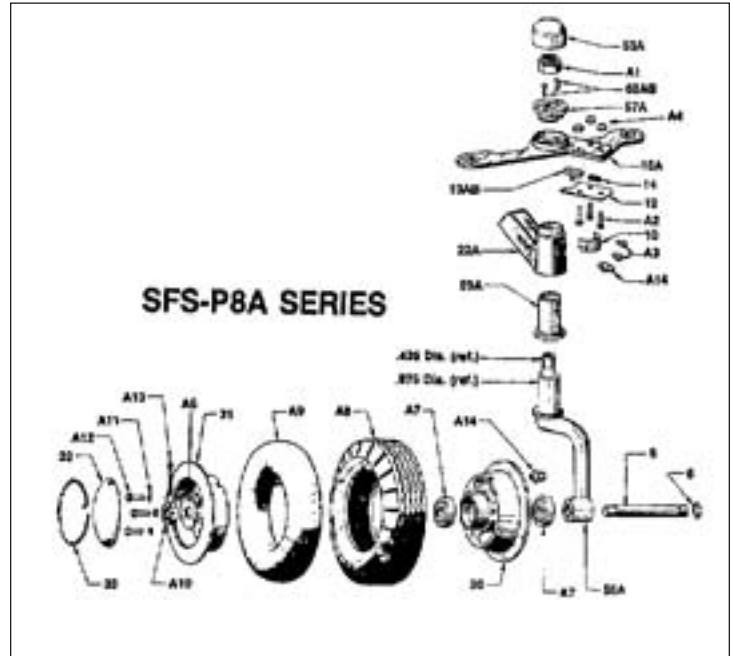

TAILWHEEL SPRINGS

TENSION TYPE - lightweight spring kit consists of 2 each - tension springs, chain and connector links. Links fit either set. Heavier tension.

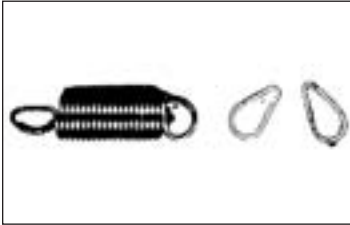

| WIDTH | SPRING LENGTH | CHAIN LENGTH | PART NUMBER | PRICE EA/SET |
|--------------------------------|---------------|--------------|-------------|--------------|
| 3/4" | 3-1/2" | 10" | TWS-2151 | 54.00 |
| 1-5/8" | 4-1/2" | 15" | TWS-3239 | 39.95 |
| Additional connector link each | | | TWL-2133 | 3.85 |

ANTI-SHIMMY CONNECTOR SPRING KIT

A high and low frequency spring is used to upset the natural frequency of the tailwheel. The lighter spring is used on the left side. Kit includes 2 - 5" chains and 4 links.

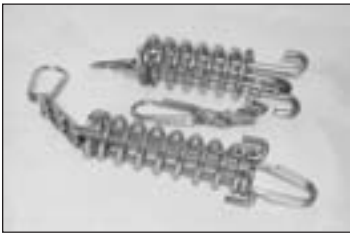

| DESCRIPTION | PART NUMBER | PRICE EACH |
|-------------------------|-------------|------------|
| Compression type (pair) | TWS-CK | 26.00 p/pr |
| Additional Chain | TWS-CN | 1.87 ft. |
| Additional Clips | TWS-CP | 3.00 ea. |

6" AZUSA REPLACEMENT WHEELS

6" Azusa aluminum replacement wheels in 3/4" & 5/8" axle size are beautifully ball-burnished for sparkle and have bead biting edges and pips to prevent tire and tube slip. The split rim design allows low cost and simple tire changing. All have 3 bolt pattern.



AZ-1105 has 3/4" tapered roller bearing, fits 3/4" axle and weighs 4.2 oz. AZ-1125 wheel is 1-5/8" od has 5/8" ball bearing which fits 5/8" axle and weighs 3.656 lbs. AZ-1127 has 3/4" standard ball bearing which fits 3/4" axle, weighs 3.625 lbs. AZ-1127 wheel width is 4" to accommodate wider tires.

| DESCRIPTION | PART NUMBER | PRICE |
|----------------------|-------------|-------|
| WHEEL 3/4" TAPER | AZ-1105 | 44.40 |
| WHEEL 5/8" BALL BEAR | AZ-1125 | 43.50 |
| WHEEL 3/4" BEARING | AZ-1127 | 45.28 |

WHEELS & BRAKES

6" HEGAR WHEELS

Popular Hegar 6" wheel for homebuilt aircraft with gross weights of 550-1100 lbs. Made from spun aluminum and polished to an attractive finish. Complete with standard hubs and 5/8" bearings. Outer sheel half includes valve stem hole. 400 x 6 fits most wheel pants applications. All may be used with Hegar disc brakes that are NOT included.



| TIRE SIZE | PART NUMBER | PRICE |
|---------------------|-------------|--------|
| 13X400X6 | HE4006 | 133.26 |
| 13X400X6 & 13X500X6 | HE5006 | 93.29 |
| 15X600X6 | HE6006 | 86.62 |

HEGAR 450X6 MX NOSEWHEEL-5/8"

Polished aluminum nosewheel features MX-style hub with 5/8" bearing. Includes valve stem hole. width: 4-1/2"



| DESCRIPTION | PART NUMBER | PRICE |
|-------------|-------------|-------|
| NOSEWHEEL | HE4506NW | 67.42 |

HEGAR 6"DISC BRAKE KT/HND LEVER

Complete hydraulic disc brake for use with Hegar wheels. Kit includes master cylinder with stick-mounted actuating lever, billet machined brake disc hubs with heat-treated discs, billet machined external calipers with heat activated metallic brake pads, 4130 axles 5/8" diameter, bleeder kit with Dextron II brake fluid, all necessary hardware and fittings, 15 feet brake line and instructions. For aircraft weighing 550-1100 lbs.



| DESCRIPTION | PART NUMBER | PRICE |
|-------------------------------|-------------|--------|
| HEGAR 6"DISC BRK KT/HND LEVER | 4400STK | 499.00 |

6" MATCO WHEEL KIT MH6BK

Designed for ultralight aircraft with weights less than 900 lbs. Work hardened 2 piece rim has a specially designed shoulder and thicker outer flange for better seal and support of tire. Wheel width of 5-3/8" accepts any 6" tire/tube combination. Precision 5/8" sealed ball bearings. Wheel is mated to a 4" single piston brake assembly developing 93,441 ft lbs of kinetic energy. Axle is 5/8" non weldable. Total kit weight is 3.7 lbs. Gold. Kit consists of 1 each wheel, brake and axle assembly.



| DESCRIPTION | PART NUMBER | PRICE |
|--------------------|-------------|--------|
| 1-WHEEL/BRAKE/AXLE | MH6BK | 254.63 |

6" MATCO WHEEL KIT

Designed for ultralight aircraft with weights less than 900 lbs. Work-hardened 2-pc rims have a specially designed shoulder and thicker outer flange for better seal and support of tire. Wheel width of 5-3/8" accepts any 6" tire/tube combination. Precision 5/8" sealed ball bearings. Wheel is mated to a 4" single piston brake assy developing 93,441 ft lbs of kinetic energy. Includes 5/8" non-weldable axle w/hardware. Total kit wt : 3.7 lbs. Silver. Kit consists of 1 each wheel, brake and axle assembly.



| DESCRIPTION | PART NUMBER | PRICE |
|-----------------------------|-------------|--------|
| 1 MATCO MH6B-S WHL/BRK/AXLE | MH6BSK | 254.63 |

6" MATCO WHEEL KIT

Matco "E series" 6" wheel, brake and axle assembly for aircraft requiring a static capacity of less than 900 lbs. Featuring an externally mounted single-piston caliper for ease of maintenance. 2 piece spun aluminum wheel offers superior strength, corrosion resistance and light weight. It uses 1-1/4" tapered roller bearings and mates with an axle. with a standard Cessna bolt hole pattern. Rated braking capacity: 118,000 ft lbs. Wheel width: 5-3/8", total assembly weight 5.8 lbs. Kits contains 1 each wheel, brake and axle.



| DESCRIPTION | PART NUMBER | PRICE |
|--------------------|-------------|--------|
| 1-WHEEL/BRAKE/AXLE | MHE6BSCK | 313.15 |

6" MATCO WHEEL KIT

6" HUB W/BEARING
BRAKE DISC
WHEEL & BRAKE - SILVER



| DESCRIPTION | PART NUMBER | PRICE |
|------------------------|-------------|--------|
| 6" HUB W/BEARING | MT-621 | 55.99 |
| BRAKE DISC | MT-D5 | 46.66 |
| WHEEL & BRAKE - SILVER | MT-MH6B-S | 250.00 |

WHEELS & BRAKES

6" MATCO WHEEL KIT W62K

6" aluminum wheel and brake and axle assembly with 3/4" tapered roller bearings for use on small aircraft such as Avid Flyer, Kitfox etc. Wheel width is 4.375" with a 2.52" bearing spacing. Wheel features light weight, superior strength and corrosion resistance. Wheel is matched with a single-piston brake assembly with the following ratings: Static capacity: 1185 lbs, load limit: 3560 lbs, kinetic energy 189,604 ft lbs. Total wheel/brake assembly weight with axle: 6.8 lbs. Wheel requires tube with 90 degree valve. Kit consists of 1 each wheel, brake and axle.



| DESCRIPTION | PART NUMBER | PRICE |
|--------------------|-------------|--------|
| 1-WHEEL/BRAKE/AXLE | W62K | 289.00 |

HEEL BRAKE ASSEMBLY

The left and right heel brake assemblies are gold anodized, weigh 1lb 4oz, made to the scott mounting system and are supplied with a Matco MC4 master cylinder. Compression type (pair)



| DESCRIPTION | PART NUMBER | PRICE EACH |
|-------------|-------------|------------|
| RIGHT | HB102 | 331.25 |
| LEFT | HB103 | 331.25 |

WASHERS 1-1/4" DIAMETER

Sold per each. Made of steel cadmium II plated. OD 2", ID 1.265, and .090 thick. For a 1-1/4" AN20 bolt or 1-1/4" axles.



| DESCRIPTION | PART NUMBER | PRICE EACH |
|-----------------------------|-------------|------------|
| WASHER EACH AN20(1-1/4"DIA) | AN960-2016 | 0.99 |

CLEVELAND MASTER CYLINDER REPAIR KITS

For Cleveland CWB10-19 and CWB10-20 master cylinder.



| FITS | PART NUMBER | PRICE |
|-------------------|-------------|-------|
| | CWB199-502 | 9.99 |
| | CWB199-505 | 8.26 |
| 10-30,A,B,C,10-72 | CWB199-512 | 10.34 |
| | CWB199-513 | 6.89 |
| | CWB199-516 | 3.84 |

CLEVELAND REPLACEMENT PARTS



| DESCRIPTION | PART NUMBER | PRICE |
|----------------------|--------------|-------|
| FOR CWB199(502)(505) | CWB095-01100 | 6.85 |
| STAT-O-SEAL | CWB095-02600 | 2.40 |
| FOR CWB199-513 KIT | CWB101-60001 | 5.95 |
| FELT-GREASESEAL | CWB154-3 | 4.75 |
| FITS 10-35 ASSEMBLY | CWB182-50 | 79.98 |

CLEVELAND BRAKE BLEEDER ADAPTER

Adapter couples onto Cleveland-type bleeder screws forming a leak-proof seal that allows proper bleeding & charging of brake lines and cylinder. A quick connect coupler on the opposite end connects to any bleeder tank or other pressurized fluid system.



| DESCRIPTION | PART NUMBER | PRICE |
|-------------------------------|-------------|-------|
| CLEVELAND BRAKE BLEEDER ADPTR | ATS1246 | 25.14 |

STRUT VALVE HI-PRESSURE

STRUT VALVE High pressure strut valve used in applications up to 5000 psi. Made of corrosion resistant steel.



| DESCRIPTION | PART NUMBER | PRICE EACH |
|-------------|-------------|------------|
| STRUT VALVE | MS28889-2 | 16.34 |